

EUGEN J. IONASCU

REGULAR OCTAHEDRA IN $\{0, 1, \dots, n\}^3$

ABSTRACT. In this paper we describe a procedure for calculating the number of regular octahedra, $\mathcal{RO}(n)$, which have vertices with coordinates in the set $\{0, 1, \dots, n\}$. As a result, we introduce a new sequence in *The Online Encyclopedia of Integer Sequences* (A178797) and list the first one hundred terms of it. We improve the method appeared in [12] which was used to find the number of regular tetrahedra with coordinates of their vertices in $\{0, 1, \dots, n\}$. A new fact proved here helps increasing considerably the speed of all programs used before. The procedure is put together in a series of commands written for Maple and it is included in an earlier version of this paper in the matharxiv. Our technique allows us to find a series of cubic polynomials $p_1(n) = (n - 1)^3$, $p_2(n) = 5(n - 3)^3$, $p_3(n) = (n - 5)^3$, $p_4(n) = 5(n - 7)^3$, $p_5(n) = (n - 9)(7n^2 - 102n + 375), \dots$, such that

$$\begin{aligned} \mathcal{RO}(n) = & p_1(n)\chi_{x \geq 1}(n) + p_2(n)\chi_{x \geq 3}(n) + p_3(n)\chi_{x \geq 5}(n) \\ & + p_4(n)\chi_{x \geq 7}(n) + p_5(n)\chi_{x \geq 9}(n) + \dots \end{aligned}$$

KEY WORDS: diophantine equations, regular octahedra, Ehrhart polynomial, sequence of integers, primitive solutions.

AMS Mathematics Subject Classification: 52C07, 05A15, 68R05, 11D09.

1. Introduction

In this article¹ we continue and, in a sense, conclude the work begun in the sequence of papers [3], [10]-[15] about equilateral triangles, regular tetrahedra, cubes, and regular octahedrons all with vertices having integer coordinates in $\{0, 1, \dots, n\}^3$. We refer to this property by saying that the various objects are in \mathbb{Z}^3 but, strictly speaking, these geometric objects are defined as being more than the set of their vertices that determines them. So, for instance, an equilateral triangle is going to be a set of three points in \mathbb{Z}^3 for which the Euclidean distances between every two of these points

¹ This work has been supported by a Columbus State University summer grant

are the same. A regular octahedron in \mathbb{Z}^3 for us is simply a list of six points in \mathbb{R}^3 , $\mathcal{O} = [A_1, A_2, B_1, B_2, C_1, C_2]$, with integers coordinates so that

$$(1) \quad \begin{cases} d(A_1, A_2) = d(B_1, B_2) = d(C_1, C_2) = \sqrt{2}\ell > 0 \\ d(A_i, B_j) = d(A_i, C_j) = d(B_i, C_j) = \ell, \quad \ell \in \mathbb{R}, \end{cases}$$

for all i 's and j 's. The number ℓ is usually referred to as the size of the side lengths of the octahedron \mathcal{O} . The main purpose of this article is to take a closer look at these objects. Probably, the simplest example of a regular octahedron with integer coordinates for its vertices, that one may think of, is

$$\mathcal{OC}_1 := [[1, 0, 0], [-1, 0, 0], [0, 1, 0], [0, -1, 0], [0, 0, 1], [0, 0, -1]], \quad \ell = \sqrt{2}.$$

Let us make the convention that although we defined \mathcal{OC}_1 as this particular octahedron, we will keep the same notation for any other integer translation of it or symmetry applied to it. In other words, we will keep the same notation for the class of all octahedrons obtained from this one by applying all the isometries of the space which leave the lattice \mathbb{Z}^3 invariant.

One of the corollaries of our previous work shows that ℓ must be of the form $n\sqrt{2}$ with $n \in \mathbb{N}$, and for each n odd, there exists at least one such octahedron which is *irreducible* in the sense that it does not arise from a smaller such octahedron by translation with an integer coordinates vector and an integer dilation. If n is even, then the octahedron is reducible. It is known that the dual of a cube is a regular octahedron and viceversa. It turns out that this idea gives a procedure to construct all such octahedrons as shown in [15]:

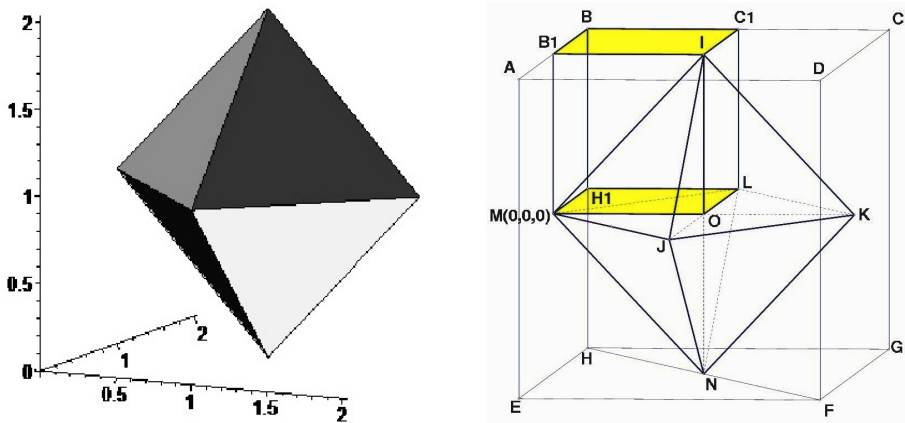

Figure 1(a): $\mathcal{OC}_1 + (1, 1, 1)$ octahedron Figure 1(b): Regular octahedron vs cube

Theorem 1. *Every regular octahedron in \mathbb{Z}^3 is the dual of a cube that can be obtained (up to a translation with a vector with integer coordinates) by doubling a cube in \mathbb{Z}^3 .*

Referring to Figure (b), we showed that if the regular octahedron $IJKLMN$ is in \mathbb{Z}^3 , then so is the cube $BB_1C_1IH_1LOM$ and vice versa. This defines a one-to-one correspondence between the classes of cubes (invariant under integer translations) and the classes regular octahedra (invariant under integer translations) in \mathbb{Z}^3 . This construction gives the next simple corollary.

Corollary 1. *The center of every regular octahedron in \mathbb{Z}^3 has integer coordinates.*

This can be easily seen by observing that the cube from which the octahedron arises has one of its vertices at the center of the octahedron center.

We are taking advantage of this corollary by writing our examples of octahedra having the center at the origin. With the definition introduced earlier if the octahedron $\mathcal{O} = [A_1, A_2, B_1, B_2, C_1, C_2]$ has the origin as its center, then $A_1 = -A_2$, $B_1 = -B_2$ and $C_1 = -C_2$ and so we can simplify the writing of \mathcal{O} to $\{\pm A_1, \pm B_1, \pm C_1\}$. Let us list a few more of such regular octahedra and introduce also a sequence of natural numbers which we are denoting by $irro(n)$, $n \in \mathbb{N}$. The next side length possible appears in the following octahedron:

$$\mathcal{OC}_2 := \{\pm[1, -2, 2], \pm[-2, 1, 2], \pm[2, 2, 1]\}, \quad \ell = 3\sqrt{2}.$$

For $\ell = 5\sqrt{2}$, we run into familiar numbers:

$$\mathcal{OC}_3 := \{\pm[4, 0, 3], \pm[3, 0, -4], \pm[0, 5, 0]\}.$$

We observe that there are obvious transformations that we can use to obtain new octahedrons from known ones. We have transformations that change the signs of the variables, for example $(x, y, z) \rightarrow (-x, y, z)$, or transformations that change the order of variables, all together a total of 48 symmetries of the space that one can use to transform a given octahedron into new one, in general (\mathcal{OC}_1 is invariant under all these transformations). So, the set of regular octahedrons centered at the origin, can be structured into classes, modulo the action of this group of symmetries. A natural question at this point is to find the number of classes, $irro(n)$, of regular tetrahedrons in \mathbb{Z}^3 which have side lengths $(2n - 1)\sqrt{2}$. One can show that $irro(1) = irro(2) = irro(3) = irro(4) = 1$. An octahedron that generates the class for $\ell = 7\sqrt{2}$ can be taken to be

$$\mathcal{OC}_4 := \{\pm[-3, 6, 2], \pm[6, 2, 3], \pm[2, 3, -6]\}.$$

We do not know how to calculate $irro(n)$ in general and we are wondering if this sequence is related with any other objects in mathematics. It is clear that this sequence is related to the number of primitive solutions $\{a, b, c\}$ ($gcd(a, b, c) = 1$) of the equation $a^2 + b^2 + c^2 = 3(2n - 1)^2$. It is very unclear how these solutions combine to give the number $irro(n)$ of classes (see Table 1). For $n = 5$ even though we have two solutions for the mentioned equation, i.e. $3(9^2) = 1^2 + 11^2 + 11^2 = 5^2 + 7^2 + 13^2$, there is still only one class ($irro(5) = 1$). We close the introduction with a table containing the range $n \in \{5, 6, \dots, 11\}$, some element in each corresponding class, the number of solutions of $a^2 + b^2 + c^2 = 3(2n - 1)^2$ (denoted here and some other places of our works by $\pi\epsilon(2n - 1)$), and $irro(n)$.

Table 1

n	An octahedron	$\pi\epsilon(2n - 1)$	$irro(n)$
5	$\{\pm[4, -1, 8], \pm[-7, 4, 4], \pm[4, 8, -1]\}$	2	1
6	$\{\pm[6, 6, -7], \pm[-2, 9, 6], \pm[9, -2, 6]\}$	3	1
7	$\{\pm[-4, 12, 3], \pm[12, 3, 4], \pm[3, 4, -12]\}$ $\{\pm[0, 13, 0], \pm[12, 0, 5], \pm[5, 0, -12]\}$	2	2
8	$\{\pm[10, -5, 10], \pm[11, 2, -10], \pm[2, 14, 5]\}$	3	1
9	$\{\pm[-12, 8, 9], \pm[12, 9, 8], \pm[1, -12, 12]\}$ $\{\pm[15, 0, 8], \pm[8, 0, -15], \pm[0, 17, 0]\}$	4	2
10	$\{\pm[-15, 6, 10], \pm[10, 15, 6], \pm[6, -10, 15]\}$ $\{\pm[6, -18, 1], \pm[17, 6, 6], \pm[6, 1, -18]\}$	4	2
11	$\{\pm[-16, 11, 8], \pm[13, 16, 4], \pm[4, -8, 19]\}$ $\{\pm[-5, 20, 4], \pm[20, 4, 5], \pm[4, 5, -20]\}$	3	2

In [12], we have shown that the number of primitive solutions of the Diophantine equation $a^2 + b^2 + c^2 = 3(2n - 1)^2$ can be calculated just in terms of the prime decomposition of $2n - 1$ and recently we used those formulae and obtained experimental data that suggests that $\pi\epsilon(n) = Cn + o(n)$, n odd, where $C \approx 0.1706$ (correct to four decimal places).

2. The new method

In [13], we improved and adapted earlier procedures for counting all cubes with vertices in $\{0, 1, \dots, n\}^3$. That allowed us to extend the sequence A098928. In this paper, the usual techniques and ideas are employed except some counting procedure that is very efficient in comparison to what we had before. We are going to treat this in the general case so, let us suppose that these objects can be either equilateral triangles, regular tetrahedrons, cubes or regular octahedrons with vertices in \mathbb{Z}^3 . For such an object, say \mathcal{O} , we can translate it, within \mathbb{Z}^3 , to \mathcal{O}' that is in the positive octant and in such

way each plane of coordinates contains at least one vertex of \mathcal{O}' . Let us denote by α_0 the number of objects in C_m obtained by applying to \mathcal{O}' all 48 possible symmetries of the cube C_m . These symmetries are generated in the following way: first we have symmetries with respect to the middle planes and compositions, for example

$$\begin{aligned} (x, y, z) &\rightarrow (m - x, y, z), & (x, y, z) &\rightarrow (m - x, m - y, z), \\ (x, y, z) &\rightarrow (m - x, m - y, m - z), \end{aligned}$$

in a total of eight including the identity, then each one of these is coupled with one of the six permutations of the variables (\mathcal{S}_6). These transformations form a group isomorphic with the group of all 3×3 orthogonal matrices having entries ± 1 and it is also known as the group of symmetries of a cube or of a regular octahedron. It is isomorphic to $S_4 \times \mathbb{Z}_2$. We are going to denote this group by \mathcal{S}_{cube} although it is usually known under the name of (extended) octahedral group and denoted simply by O_h .

If we think of α_0 as the cardinality of

$$Orbit(\mathcal{O}') := \{s(\mathcal{O}') | s \in \mathcal{S}_{cube}\},$$

which is the same as the cardinality of the group factor $\mathcal{S}_{cube}/\mathcal{G}$, where \mathcal{G} is the subgroup of \mathcal{S}_{cube} of those symmetries that leave \mathcal{O}' invariant. The structure of subgroups of \mathcal{S}_{cube} is known and for each divisor of 48 there is a subgroup of that order. Hence, we expect α_0 to be in the set $\{1, 2, 3, 4, 6, 8, 12, 16, 24, 48\}$ and most of the time to be 48 since an arbitrary object \mathcal{O}' in C_m is unlikely to be invariant under any of the symmetries of \mathcal{S}_{cube} .

Then, we denote by α , the cardinality of the set of all the objects counted in α_0 and their (all possible) integer translations that leave the resulting objects in C_m . Also, we denote by β the number of objects counted in α which are in $\{0, 1, \dots, m\}^2 \times \{0, 1, \dots, m - 1\}$. Finally, let us denote by γ the number of objects counted in β which are in $\{0, 1, \dots, m\} \times \{0, 1, \dots, m - 1\}^2$. Then, we found a formula that gives the number of objects obtained from \mathcal{O} , denoted here and in [11] by $N(\mathcal{O}, k)$, under all symmetries and translation that leaves the resulting object in $\{0, 1, \dots, k\}^3$, $k \geq m$.

This fact has been essentially proved in Theorem 2.2 in [11]. The formula that gives this number is

$$(2) \quad N(\mathcal{O}, k) = (k - m + 1)^3 \alpha - 3(k - m)(k - m + 1)^2 \beta + 3(k - m + 1)(k - m)^2 \gamma.$$

Let us suppose that the object \mathcal{O} can be squeezed within a box of dimensions $m \times n \times p$ ($m \geq n \geq p$), i.e. up to symmetries and translations, \mathcal{O} can be transformed to \mathcal{O}' fitting snugly into

$$B_{m,n,p} := \{0, 1, \dots, m\} \times \{0, 1, \dots, n\} \times \{0, 1, \dots, p\}.$$

We can similarly consider all eight reflections compatible with the box $B_{m,n,p}$ of the form

$$\begin{aligned} (x, y, z) &\rightarrow (m - x, y, z), & (x, y, z) &\rightarrow (m - x, n - y, z), \\ (x, y, z) &\rightarrow (m - x, n - y, p - z), & & \text{etc.} \end{aligned}$$

Let us denote the group of these transformations by \mathcal{S}_b . We notice that each one of these transformation leaves the object \mathcal{O}' inside the box $B_{m,n,p}$. From case to case, depending of what the values m , n and p are, we may have the result of some or all of the permutation transformations applied to \mathcal{O}' still in $B_{m,n,p}$. Hence, we will denote by $\omega(\mathcal{O})$ the cardinality of the set

$$\text{BoxOrbit}(\mathcal{O}') := \{[s_1 \circ s_2](\mathcal{O}') \in B_{m,n,p} | s_1 \in \mathcal{S}_b, s_2 \in \mathcal{S}_6\}.$$

Let us look at an example. Suppose \mathcal{O} (equal with \mathcal{O}') is the equilateral triangle given by its vertices:

$$\{[0, 2, 2], [5, 7, 0], [7, 0, 1]\}.$$

We observe that $\mathcal{O} \in B_{7,7,2}$. Then one can check that $\text{BoxOrbit}(\mathcal{O})$ is the collection of eight triangles

$$\begin{aligned} \mathcal{O}, \{[0, 0, 1], [2, 7, 0], [7, 2, 2]\}, \{[0, 0, 1], [2, 7, 2], [7, 2, 0]\}, \{[0, 2, 0], [5, 7, 2], [7, 0, 1]\}, \\ \{[0, 5, 0], [5, 0, 2], [7, 7, 1]\}, \{[0, 5, 2], [5, 0, 0], [7, 7, 1]\}, \{[0, 7, 1], [2, 0, 0], [7, 5, 2]\}, \\ \{[0, 7, 1], [2, 0, 2], [7, 5, 0]\}, \end{aligned}$$

so $\omega(\mathcal{O}) = 8$. It turns out that $\alpha_0(\mathcal{O}) = 48$, $\alpha(\mathcal{O}) = 144$, $\beta(\mathcal{O}) = 40$ and $\gamma(\mathcal{O}) = 0$. Formula (2) becomes

$$N(\mathcal{O}, k) = 24(k - 1)(k - 6)^2, \quad k \geq 7.$$

It turns out the this factorization is not accidental and the following alternative to (2) is true.

Theorem 2. *Given \mathcal{O} , one of the objects mentioned before, and $B_{m,n,p}$ the smallest box containing a translation of \mathcal{O} ($m \geq n \geq p$), we let $u = m - n$, $v = n - p$, and*

$$\Delta = \omega(\mathcal{O})(k - m + 1)(k - n + 1)(k - p + 1).$$

Then the number of distinct objects in the cube $B_{k,k,k}$ ($k \geq m$), obtained from \mathcal{O} by all possible integer translations and symmetries is equal to

$$(3) \quad N(\mathcal{O}, k) = \begin{cases} \Delta & \text{if } u = v = 0, \\ 3\Delta & \text{if } u \text{ or } v \text{ is } 0, \\ 6\Delta & \text{if } u \text{ and } v > 0. \end{cases}$$

Proof. The case $u = v = 0$ implies $\omega(\mathcal{O}) = \alpha_0(\mathcal{O}) = \alpha(\mathcal{O})$ and $\beta(\mathcal{O}) = \gamma(\mathcal{O}) = 0$ because there is no room to shift the orbit $Orbit(\mathcal{O}')$ inside of $B_{m,m,m}$. The formula follows from (2).

Let us look into the case $u > 0$ and $v > 0$. We begin by observing that each integer translation of the box $B_{m,n,p}$ in all possible ways inside $B_{k,k,k}$ will give $\omega(\mathcal{O})$ more copies of \mathcal{O} . There is no overlap between these copies because neither one of them can be inside of two distinct translations of $B_{m,n,p}$. This is due to the minimality of m , n and p . We get Δ such copies by counting all possible translations. Since m , n and p are all distinct, the box $B_{m,n,p}$ can be positioned first with the biggest of its dimensions along one of the directions given by the axis of coordinates, that is three different ways, and for each such position the next largest dimension can be positioned along the two remaining directions. The minimality of m , n and p makes the six different situations generate distinct objects. This explains the factor of six that appears in (3) for this situation.

In the last case, the box $B_{m,n,p}$ has two of its dimensions the same, so there are only three possibilities to arrange the box before one translates it. To see that we get all possible translates and symmetries of \mathcal{O} by this counting, we can start with one copy \mathcal{O}' . Construct the minimum box around it. In terms of its position and dimensions, we know in what of the six or three cases we are. We transform it into the standard standard position, $B_{m,n,p}$, and look at the corresponding object, \mathcal{O}'' . The transformations involved form a group of transformations generated by the permutations of the coordinates, the reflections into the axes and integer translations. Every transformation in this group, say $g = \tau \circ \sigma \circ \pi$ with π a permutation, σ a reflection or a composition of reflections and τ a translation, which satisfies $g(\mathcal{O}) = \mathcal{O}''$ determines a representation $(s_1 \circ s_2)(\mathcal{O}) = \mathcal{O}''$ with $s_1 \in \mathcal{S}_b$, $s_2 \in \mathcal{S}_6$ as in the definition of $\omega(\mathcal{O})$. This can be done by taking $s_2 = \pi$ and $s_1 = \tau \circ \sigma$. This is true again because of the minimality of the box $B_{m,n,p}$, i.e. there is only one integer translation that takes a reflected box $B'_{m,n,p}$ into $B_{m,n,p}$. ■

This new way of counting is more efficient from a computational point of view because ω is simply no bigger than 48, as opposed to the previous situation when α , β and γ could turn out to be big numbers and so the number of iterations for computing them would be also large. Roughly speaking, this counting factors out fast the problem with the integer translations.

As an example, let us consider

$$OC_2 = \{[0, 0, 1], [0, 3, 4], [1, 4, 0], [3, 0, 4], [4, 1, 0], [4, 4, 3]\}.$$

The minimal box here is $B_{4,4,4}$ and after rotating OC_2 in all possible ways (Figure 2(b)) we get $\omega(OC_2) = 4$.

Figure 2(a): OC_2 octahedron

Figure 2(b): Four octahedrons in the box

The idea of calculations is basically the same as in [13], in which we have constructed a list of irreducible cubes that are used to generate all the other cubes in $B_{k,k,k}$. Here, we are using Theorem 1, to construct a similar list of irreducible regular octahedra. For the reader interested in the Maple code we have included that in an earlier version of this paper (see [16]).

The first one hundred terms of A178797 were calculated with the Maple code mentioned above in just a few minutes. We include them here for the convenience of the reader.

0, 1, 8, 32, 104, 261, 544, 1000, 1696, 2759,	n=1...10
4296, 6434, 9352, 13243, 18304, 24774, 32960, 43223, 55976, 71752,	n=11...20
90936, 113973, 141312, 173436, 210960,	n=21...25
254587, 305000, 364406, 432824, 511421,	n=26...30
600992, 702556, 817200, 946131, 1090392,	n=31...35
1251238, 1430072, 1629391, 1850064, 2094276,	n=36...40
2363616, 2659813, 2984600, 3341660, 3731720,	n=41...45
4156689, 4618480, 5119292, 5661600, 6248705,	n=46...50
6882808, 7568126, 8306520, 9104339, 9962320,	n=51...55
10888762, 11882896, 12949661, 14090952, 15311286,	n=56...60
16613736, 18001975, 19479680, 21052826, 22724576,	n=61...65
24500175, 26383240, 28387456, 30510616, 32758963,	n=66...70
35136544, 37656214, 40317328, 43125329, 46085496,	n=71...75
49207224, 52493112, 55954267, 59592272, 63415296,	n=76...80
67428832, 71642127, 76059704, 80701546, 85565064,	n=81...85
90662451, 95997360, 101592122, 107443264, 113561009,	n=86...90
119951832, 126644136, 133629672, 140916757, 148513712,	n=91...95
156444624, 164706400, 173308509, 182260568, 191575248.	n=96...100

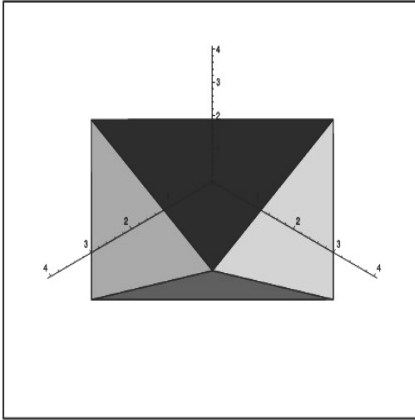
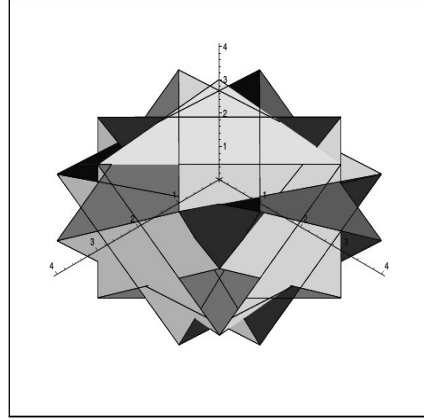
3. Cubic polynomials as lower bounds for $\mathcal{RO}(n)$

We include here a series of polynomials which appear naturally in the calculation of $\mathcal{RO}(n)$ as a result of applying our method. These are polynomials of degree three as given by Theorem 2. There are other type of cubic polynomials associated to lattice polytopes (convex hull of finitely many points in the lattice \mathbb{Z}^3). We are referring to the Ehrhart polynomial, $\mathcal{L}_{\mathcal{OC}}(t)$, which is “dually” defined, in a certain sense, as the number of lattice points inside the dilation $t\mathcal{OC}$, $t \in \mathbb{N}$. We believe there may be a connection with these polynomials. In [18], we study this subject in more detail. We recommend [2] for a good investigation of these polynomials. Here we just want to include some of them for comparison.

If we start with $\mathcal{OC}_1 = \text{class of } \{[0, 1, 1], [1, 0, 1], [1, 1, 0], [1, 1, 2], [1, 2, 1], [2, 1, 1]\}$, its contribution to $\mathcal{RO}(n)$ ($n \geq 2$) is $p_1(n) = (n-1)^3$ since $\omega(\mathcal{OC}_1) = 1$ and $\Delta = 0$. Its Ehrhart polynomial is $\mathcal{L}_{\mathcal{OC}_1}(t) = \frac{4t(t^2+2)}{3} + 2t^2 + 1$.

For $\mathcal{OC}_2 = \text{class of } \{[0, 0, 1], [0, 3, 4], [1, 4, 0], [3, 0, 4], [4, 1, 0], [4, 4, 3]\}$, brings a contribution of $4(n-3)^3$ if $n > 3$. On the other hand $2\mathcal{OC}_1$ fits perfectly in C_n ($n \geq 4$) bringing $(n-3)^3$ more “copies”. This amounts to $p_2(n) = 5(n-3)^3$ the number of regular octahedrons of side lengths $3\sqrt{2}$ in C_n . Putting together the total number of regular octahedrons of side lengths $\sqrt{2}$, $2\sqrt{2}$, or $3\sqrt{2}$, in C_n ($n \geq 4$), is $(n-1)^3 + 5(n-3)^3$. This gives the inequality, which is sharp in the sense it becomes equality for $n = 4$, but of course is very coarse if n is way bigger than 4:

$$\mathcal{RO}(n) \geq 6n^3 - 48n^2 + 138n - 136, \quad n \geq 4.$$

The Ehrhart polynomial for \mathcal{OC}_2 is $\mathcal{L}_{\mathcal{OC}_2}(t) = 36t^3 + 9t^2 - t + 1$. One knows that the coefficient of t^3 is always the volume of the polytope which for regular octahedrons is simply $\frac{4}{3}(2k+1)^3$ if the side lengths are $(2k+1)\sqrt{2}$. Another interesting fact is that the constant term is always equal to 1 (the case of non-convex polyhedra do not fall into the definition of a polytope).

For $n \geq 8$, we only can fit in C_n , besides all the octahedrons we have counted before, the trace of the classes $3\mathcal{OC}_1$, $4\mathcal{OC}_1$, and $2\mathcal{OC}_2$. This implies

$$\mathcal{RO}(n) \geq (n-1)^3 + 5(n-3)^3 + (n-5)^3 + 5(n-7)^3, \quad n \geq 8.$$

For $n \geq 10$, since

$$\mathcal{OC}_3 = \text{class of } \{[0, 5, 1], [1, 5, 8], [4, 0, 4], [4, 10, 4], [7, 5, 0], [8, 5, 7]\}$$

this class brings a contribution of $6(n-7)^2(n-9)$ copies in $\mathcal{RO}(n)$ according to Theorem 2 ($\omega(\mathcal{OC}_3) = 1$, $u = v = 2 > 0$). Adding the contributions

from $5\mathcal{OC}_1$ we get a total of $p_5(n) = (n-9)(7n^2 - 102n + 375)$ of all regular octahedron in C_n ($n \geq 10$) with side lengths $5\sqrt{2}$. Then at this point we have

$$\begin{aligned} \mathcal{RO}(n) \geq & (n-1)^3 + 5(n-3)^3 + (n-5)^3 + 5(n-7)^3 \\ & + 6(n-7)^2(n-9) + (n-9)^3, \quad n \geq 10 \end{aligned}$$

or

$$\mathcal{RO}(n) \geq 19n^3 - 333n^2 + 2241n - 5351, \quad n \geq 10.$$

The Ehrhart polynomial for \mathcal{OC}_3 is $\mathcal{L}_{\mathcal{OC}_3}(t) = \frac{500}{3}t^3 + 10t^2 + \frac{16}{3}t + 1$. The second coefficient can be calculated in terms of the surface area normalized by the area of a fundamental domain of the sublattice contained in the plane of that particular face. The third coefficient, the coefficient of t , is the most difficult to compute.

Let us close with the observation that this pattern of having a sequence of polynomials p_i which enter in the calculation of $\mathcal{RO}(n)$ at odd integers continues. This is due to the next simple fact.

Proposition 1. *Every octahedron in \mathbb{Z}^3 which is minimally contained in a box $B_{m,n,p} = [0, m] \times [0, n] \times [0, p]$, has the property that*

$$\max(m, n, p) \text{ is even.}$$

Proof. Without loss of generality we may assume that the maximum of the coordinates, is say m . The minimality of the box insures that there exists a vertex $V = (m, u, v)$ of the octahedron and let $W = (a, b, c)$ the vertex diagonally opposite of the octahedron. Due to the symmetry of the regular octahedron, if any of the adjacent vertices to V are on the plane $x = m$, their corresponding diagonally opposite vertices will be on the plane $x = a$. Hence, if a is not zero we can find a smaller box containing a translate of the octahedron. Since $a = 0$ the center of the octahedron, $(\frac{m}{2}, \frac{u+b}{2}, \frac{v+c}{2})$, must have integer coordinates and so, m must be even. ■

References

- [1] ANKENY N.C., Sums of three squares, *Proceedings of AMS*, 8(2)(1957), 316-319.
- [2] BECK M., ROBINS S., Computing the Continuous Discretely: Integer-Point Enumeration in Polyhedra, *Undergraduate Texts in Mathematics*, Springer-Verlag, New York, 2007; also available at <http://math.sfsu.edu/beck/ccd.html>.
- [3] CHANDLER R., IONASCU E.J., A characterization of all equilateral triangles in \mathbb{Z}^3 , *Integers*, Art. A19 of Vol. 8(2008).

- [4] COOPER S., HIRSCHHORN M., On the number of primitive representations of integers as a sum of squares, *Ramanujan J.*, 13(2007), 7-25.
- [5] COX D.A., *Primes of the Form $x^2 + ny^2$: Fermat, Class Field Theory, and Complex Multiplication*, Wiley-Interscience, (1997).
- [6] GUY R., *Unsolved Problems in Number Theory*, Springer-Verlag, (2004).
- [7] GROSSWALD E., Representations of Integers as Sums of Squares, *Springer Verlag*, New York, (1985).
- [8] SCHOENBERG I.J., Regular simplices and quadratic forms, *J. London Math. Soc.*, 12(1937), 48-55.
- [9] HIRSCHHORN M.D., SELLERS J.A., On representations of numbers as a sum of three squares, *Discrete Mathematics*, 199(1999), 85-101.
- [10] IONASCU E.J., A parametrization of equilateral triangles having integer coordinates, *Journal of Integer Sequences*, 10(09.6.7.)(2007).
- [11] IONASCU E.J., Counting all equilateral triangles in $\{0, 1, 2, \dots, n\}^3$, *Acta Math. Univ. Comenianae*, LXXVII, 1(2008), 129-140.
- [12] IONASCU E.J., Regular tetrahedra with integer coordinates of their vertices, *Acta Math. Univ. Comenianae*, LXXX, 2(2011), 161-170.
- [13] IONASCU E.J., OBANDO R., Cubes in $\{0, 1, 2, \dots, n\}^3$, to appear in *Integers* (2012), arXiv:1003.4569.
- [14] IONASCU E.J., A characterization of regular tetrahedra in \mathbb{Z}^3 , *J. Number Theory*, 129(2009), 1066-1074.
- [15] IONASCU E.J., MARKOV A., Platonic solids in \mathbb{Z}^3 , *J. Number Theory*, 131(2011), 138-145.
- [16] IONASCU E.J., Counting all regular octahedrons in $\{0, 1, \dots, n\}^3$, arXiv:1007.1655v1.
- [17] LARROSA I., Solution to Problem 8, http://faculty.missouristate.edu/l/lesreid/POW08_03.html.
- [18] IONASCU E.J., Platonic lattice polytopes and their Ehrhart polynomial, (to appear).
- [19] ROSEN K., *Elementary Number Theory*, Fifth Edition, Addison Wesley, 2004.
- [20] SLOANE N.J.A., *The On-Line Encyclopedia of Integer Sequences*, 2005, published electronically at <http://oeis.org/>.

EUGEN J. IONASCU
DEPARTMENT OF MATHEMATICS
COLUMBUS STATE UNIVERSITY
4225 UNIVERSITY AVENUE
COLUMBUS, GA 31907
HONORIFIC MEMBER OF THE ROMANIAN INSTITUTE
OF MATHEMATICS „SIMION STOILOW”
e-mail: ionascu@columbusstate.edu

Received on 15.05.2011 and, in revised form, on 10.07.2011.